









**Silla Ejecutiva TA61 Mesh
SKU 1283**



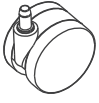
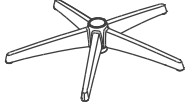

Manual de Instalación

User Manual

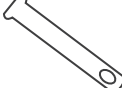
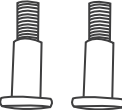
Accessories table (subject to actual size; one for each model of screw and washer)

				
5 wheels	1 chair leg	1 gas lift	1 connected backrest	1 hex wrench
				Note: Before installing the chair, please classify the screws and measure the length of the screws for installation.
2 screw covers	2 pin	1 latch (8 * 45)	2 handrail screws (8 * 36)	

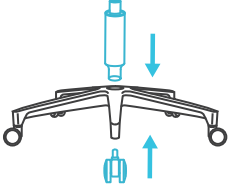
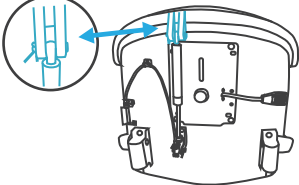
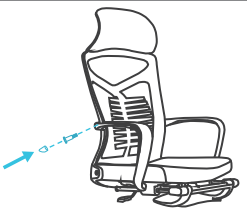
Installation diagram (subject to actual size)

	
1 1.Press the wheels into the chair leg; 2.Place the gas lift into the middle hole of the chair leg.	2 1.Connect the backrest to the gas lift and insert it with the 8 * 45 latch; 2.Penetrates the latch hole with a pin to fix it.
	
3 1.Connect the armrest to the backrest with 2 (8 * 36) handrail screws; 2.Push the screw cover into the screw hole.	4 Align the upper part of the assembled chair with the gas lift, and the chair is installed.
0 1 2 3 4 5 6 7 8 9 10 cm	

Installation Precautions

- Please read the installation instructions (picture) of all accessories carefully before installation, and master the installation steps and methods.
- Check whether the accessories are complete and damaged.
- To avoid injury during installation, it is recommended that you wear gloves.
- Choose a spacious and clean site when installing. The paper is laid flat on the ground; so as to prevent the components from colliding with the ground during installation.



Precautions for use



- Please note that when using it, place it on a flat ground. This product can only be used by one person and only one person.
- To avoid using the wrong screws, please fix all the screws before tightening them.
- Please don't let the child sit on the chair alone if he is under 5 year-old;
- Please do not sit on the armrests, as it may cause damage and danger to the chair.
- Please do not stand on the chair or use it as a ladder or step.

Manual de usuario

Mesa de accesorios (sujeto al tamaño real; uno para cada modelo de tornillo y arandela)







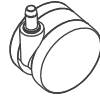
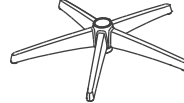

				
5 ruedas	Una pata de la silla	1 pistón de gas	Un respaldo conectado	1 llave hexagonal
				Nota: Antes de instalar la silla, clasifique los tornillos y mida la longitud de los tornillos para la instalación.
2 cubiertas de tornillo	2 pin	1 pin (8 * 45)	2 tornillos de barandilla (8 * 36)	

Diagrama de instalación (sujeto al tamaño real)

	
1 1.Presione la rueda en el pie de la silla; 2.Coloque el pistón de gas en el orificio central de la pata de la silla.	2 1.Conecte el respaldo a la barra neumática e insértelo con 8 * 45 pines; 2.Pintar el orificio del alfiler con un alfiler para arreglarlo.
	
3 1.Conecte el reposabrazos al respaldo con tornillos de reposabrazos 8 * 36; 2.Empuje la cubierta del tornillo en el orificio del tornillo.	4 Alinee la parte superior de la silla ensamblada con el pistón de gas y la silla está instalada.
0 1 2 3 4 5 6 7 8 9 10 cm	

Consideraciones de instalación

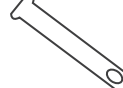
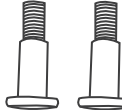
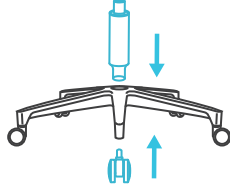
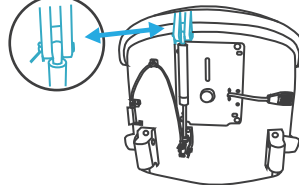
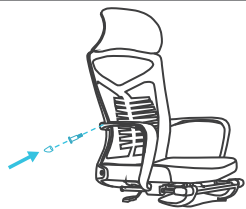
- Lea atentamente las instrucciones de instalación (imagen) de todos los accesorios antes de la instalación, y domine los pasos y métodos de instalación.
- Compruebe si los accesorios están completos y dañados.
- Para evitar lesiones durante la instalación, se recomienda que use guantes.
- Elija un sitio espacioso y limpio cuando realice la instalación. El papel se coloca plano sobre el suelo para evitar que los componentes choquen con el suelo durante la instalación.



Precauciones de uso



- Tenga en cuenta que cuando lo utilice, colóquelo en un suelo plano. Este producto sólo puede ser utilizado por una persona y sólo una persona.
- Para evitar el uso de tornillos incorrectos, fíjelos antes de apretarlos.
- No permita que los niños menores de 5 años se sienten solos en la silla.
- No se siente en los reposabrazos, ya que puede dañar y dañar la silla.
- Por favor, no se pare en la silla y úsela como escalón o escalera.